



ICC-ES Evaluation Report ESR-1662

Reissued August 2022

Revised June 2023

This report is subject to renewal August 2024.

DIVISION: 03 00 00—CONCRETE
Section: 03 41 00—Precast Structural Concrete

REPORT HOLDER:

SUPERIOR WALLS OF AMERICA, LTD.

EVALUATION SUBJECT:

**SUPERIOR WALLS XI AND XI PLUS PRECAST
CONCRETE FOUNDATION WALLS**

ADDITIONAL LISTEES:

**SUPERIOR WALLS BY ADVANCED CONCRETE
SYSTEMS, INC.**

SUPERIOR WALLS OF CENTRAL VIRGINIA

**SUPERIOR WALLS BY COLLIER FOUNDATION
SYSTEMS INC.**

**SUPERIOR WALLS BY WARRIOR PRECAST, LLC
DBA: SUPERIOR WALLS OF EAST TENNESSEE**

**SUPERIOR WALLS SYSTEMS, LLC
DBA: SUPERIOR WALLS OF NORTH CAROLINA**

**NORTHEAST PRECAST
DBA: SUPERIOR WALLS OF NEW JERSEY**

SUPERIOR WALLS OF UPSTATE NEW YORK

**WEAVER SUPERIOR WALLS, LLC
DBA: SUPERIOR WALLS BY WEAVER PRECAST**

GREAT LAKES SUPERIOR WALLS

SUPERIOR CONCRETE BLOCK COMPANY

ROCKY MOUNTAIN PRECAST, LLC

1.0 EVALUATION SCOPE

Compliance with the following codes:

- 2021, 2018, 2015, 2012, 2009 and 2006 *International Building Code*® (IBC)

- 2021, 2018, 2015, 2012, 2009 and 2006 *International Residential Code*® (IRC)

Properties evaluated:

- Structural
- Fire-resistance rating
- Surface burning characteristics
- Dampproofing
- Thermal Barrier

Attributes verified:

- See Section 3.0

2.0 USES

The Superior Walls Xi and Xi Plus Precast Concrete Foundation Walls (including basement walls) are used to support wood frame construction.

3.0 DESCRIPTION

The Superior Walls Xi and Xi Plus Precast Concrete Foundation walls are formed from 5,000 psi (34.4 MPa) compressive strength normal-weight concrete that contains synthetic fibers.

Superior Walls Xi and Xi Plus Precast Concrete Foundation Walls consist of a 1³/₄-inch-thick (44 mm) exterior face shell, monolithically cast with 10¹/₄-inch-wide (260 mm) top and bottom bond beams, and 2¹/₄-inch-by-7¹/₂-inch (57 mm by 190.5 mm) concrete studs at 24 inches (610 mm) on center.

The only difference between the Xi and Xi Plus is that the shell is bonded to various combinations of rigid foam boards on the inside face. For the Xi product, there are five insulation options: the first is 2¹/₂-inch-thick (63.5 mm) rigid cellular polystyrene; the second option is a nominal 2¹/₂-inch-thick (63.5 mm) rigid cellular phenolic foam insulation; the third option is an insulation assembly consisting of 2-inch (50.8 mm) rigid cellular polystyrene and a 1¹/₂-inch (12.7 mm) layer of polyisocyanurate insulation; the fourth option is an insulation assembly consisting of 1¹/₂-inch (38.1 mm) rigid cellular polystyrene and a 1-inch (25.4 mm) layer of polyisocyanurate insulation; and the fifth option is 2¹/₂-inch-thick (63.5 mm) polyisocyanurate. The Xi Plus product uses a 5-inch insulation assembly consisting of 4¹/₂-inch (114.3 mm) rigid cellular polystyrene and a 1¹/₂-inch (12.7 mm) layer of polyisocyanurate insulation on the inside face. Each stud is wrapped with 1-inch-thick (25.4 mm) expanded polystyrene insulation on three exposed sides and faced with a galvanized steel channel for interior finish fastening. Chase openings with knockouts are

provided in each stud for plumbing and electrical wiring. All insulation is factory installed to the precast concrete walls and must be as described in Superior Walls' approved quality control documentation.

Panels are available in heights of 4 feet (1219 mm), 8 feet 2 inches (2489 mm), 9 feet (2743 mm) and 10 feet (3048 mm), with corresponding weights of 170, 303, 329 and 361 lb/ft (253, 451, 490 and 537 kg/m), respectively. The panels are available in various lengths. See Figures 1 and 2.

The attributes of the wall panels have been verified as conforming to the provisions of (i) CALGreen Sections A4.404.3.3 for premanufactured building systems; (ii) ICC 700-2015 and ICC 700-2012 Section 601.5 and 11.601.5 for prefabricated components; and (iii) ICC 700-2008 Section 601.5 for prefabricated components. Note that decisions on compliance for those areas rest with the user of this report. The user is advised of the project-specific provisions that may be contingent upon meeting specific conditions, and the verification of those conditions is outside the scope of this report. These codes or standards often provide supplemental information as guidance.

4.0 DESIGN AND INSTALLATION

4.1 Design Details:

Backfill material must not exceed 100 lbf/ft²/ft (1602 kg/m²/m) equivalent fluid pressure for the 4-foot (1219 mm), 8-foot-2-inch (2489 mm), 9-foot (2743 mm) and 10-foot tall (3048 mm) Superior Walls. The walls have a combined (ledger plus wall loads above the foundation wall) maximum allowable axial compressive load of 7,500 lbf/ft (109,453 N/m).

Use of Superior Walls Xi and Xi Plus walls with a brick ledge is limited to an allowable load of 2,900 lbf/ft (42 320 N/m) on the brick ledge, which is to be considered as part of the allowable load of the wall noted in this section.

Above-grade foundation stem wall applications in which negative transverse loads (such as leeward side wind pressure) in accordance with the applicable code are developed, must be limited to applications where the negative design wind pressure does not exceed 80 psf (3.83 kN/m²). Above-grade foundation stem wall applications in which positive transverse wind loads, in accordance with the applicable code, are developed must be limited to applications where the allowable wind pressure does not exceed 155 psf (7.42 kN/m²).

The allowable racking shear load on the Superior Xi and Xi Plus foundation walls is limited to a maximum of 500 pf (7300 N/m). Construction using the Superior Walls Xi and Xi Plus system is limited to those Seismic Design Categories specified in Section 5.7.

Use of Superior Walls Xi and Xi Plus walls with beam pockets utilizing two support studs is limited to applications where the maximum allowable load applied to the beam pocket does not exceed 16,000 lbf (71 200 N) for a 10-foot-high (3048 mm) panel and 13,000 lbf (57 800 N) for shorter heights. Other beam pocket configurations are outside the scope of this report.

Beam pockets must be designed and constructed in accordance with the details, dimensions and specific loading limitations given in the engineered design drawings. See Figure 3 for typical beam pocket details.

Design of the footing supporting Superior Walls Xi and Xi Plus walls must be in accordance with the applicable code. The footing must extend below the frost line of the locality, as required by the applicable code.

For jurisdictions adopting the IRC, installation of Superior Walls Xi and Xi Plus walls on gravel footings is permitted as noted in IRC Section R401.2, provided the construction details comply with Section R403.4 and the details noted in Table 1 of this report.

The capacity of the bolted connection at the top and bottom of the panels, using 1/2-inch-diameter-by-2 1/2-inch-long (12.7 mm by 63.5 mm) hex head bolts through the bond beams and a 1/2-inch-diameter-by-5 1/2-inch-long (12.7 mm by 140 mm) hex head bolt through the footing beams, to transfer loads induced by lateral loads in the plane of the wall, is limited to 1,500 lbf (6675 N). See Figure 4 for typical details.

Details involving openings in the foundation walls have not been evaluated and are beyond the scope of this report.

The Superior Xi and Xi Plus walls must be laterally supported at the top and bottom of the panels.

4.2 Fire-resistance-rated Wall Construction:

With the addition of two layers of 5/8-inch (15.9 mm) Type X gypsum wallboard complying with ASTM C1396, attached to the stud facing in accordance with the applicable code, Superior Walls Xi and Xi Plus walls with a maximum allowable axial compressive load of 3,000 lbf/ft (43 779 N/m) (including ledger loads) have a two-hour fire-resistance rating.

4.3 Dampproofing:

Superior Walls Xi and Xi Plus walls have been evaluated as an alternative method of providing foundation wall dampproofing; therefore, no additional dampproofing is required.

4.4 Thermal Barrier:

A code-prescribed thermal barrier separating the foam plastic from the interior of the building is not required based on testing conducted in accordance with Section 2603.9 of the 2021, 2018, 2015, 2009, and 2006 IBC (Section 2603.10 of the 2012 IBC) and Section R316.6 of the IRC (Section R314.6 for the 2006 IRC).

4.5 Installation Details:

Superior Walls Xi and Xi Plus walls must be installed in accordance with this report and the design details and calculations, as noted in Section 5.5 of this report.

Construction details noted in Superior Walls documents such as the *Builder Guideline Booklet*, have not been evaluated and are beyond the scope of this report.

5.0 CONDITIONS OF USE

The Superior Walls Xi and Xi Plus Precast Concrete Foundation Walls described in this report comply with, or are suitable alternatives to what is specified in, those codes listed in Section 1.0 of this report, subject to the following conditions:

- 5.1 Superior Walls Xi and Xi Plus walls must be manufactured, identified and installed in accordance with this report and the information required by Section 5.5 of this report.
- 5.2 Where underground water investigation, required by the applicable code, indicates that a hydrostatic pressure condition exists, the foundation wall must be waterproofed in accordance with the applicable code. Evaluation of the waterproofing material is outside the scope of this report.
- 5.3 Connection of adjacent Superior Walls Xi and Xi Plus walls must be inspected to verify application of the sealant and bolts in accordance with the submitted design drawings.

- 5.4 Soil capacity of the site must be consistent with the requirements of the applicable code. For jurisdictions adopting the IRC, the soil capacity of the site, in lieu of a complete geotechnical evaluation, must be assumed to have the load-bearing values specified in IRC Table R401.4.1.
- 5.5 Design calculations and drawings must be submitted to the code official for approval. The documents must be prepared by a registered design professional where required by the statutes of the jurisdiction in which the project is to be constructed. The design calculations and details must address, at a minimum, the following:
- Details of waterproofing, if applicable.
 - Depth of footing and footing specifications consistent with this report.
 - Investigation of resistance to overturning and uplift forces.
 - Details for lateral support of the top and bottom of Superior Walls Xi and Xi Plus walls.
 - Verification that the loading requirements at the jobsite do not exceed the allowable loads and details (including the foundation details) noted in Section 4.1 of this report. The calculations must include verification that the combined loading conditions, such as out-of-plane and vertical loads, do not exceed the allowable loads noted in this report.
- 5.6 Installation must be done by Superior Walls–certified installers.
- 5.7 Superior Walls Xi and Xi Plus walls used as lateral force–resisting systems are limited to Seismic Design Category A or B under the IBC and to Seismic Design Category A, B or C under the IRC.
- 5.8 Superior Walls must be manufactured at the locations noted under “Additional Listees” in this report, in accordance with the Superior Walls of America, Ltd., Quality Assurance Manual, dated September 2014, and with inspections by ICC-ES.
- 6.0 EVIDENCE SUBMITTED**
- 6.1 Data in accordance with the ICC-ES Acceptance Criteria for Foam Plastic Insulation (AC12), dated June 2015 (Editorially revised December 2020), including a report of a fire test in accordance with 2603.9 of the 2021, 2018, 2015, 2009, and 2006 IBC (Section 2603.10 of the 2012 IBC).
- 6.2 Results of water permeability tests conducted in accordance with ASTM E96.
- 6.3 Data in accordance with the ICC-ES Acceptance Criteria for Concrete Floor, Roof and Wall Systems and Concrete Masonry Wall Systems (AC15), dated February 2010 (Editorially revised March 2021); including reports of beam pocket tests.
- 6.4 Report of fire-resistance tests conducted in accordance with ASTM E119.
- 7.0 IDENTIFICATION**
- 7.1 The ICC-ES mark of conformity, electronic labeling, or the evaluation report number (ICC-ES ESR-1662) along with the name, registered trademark, or registered logo of the report holder and/or listee must be included in the product label.
- 7.2 In addition, each Superior Walls Xi and Xi Plus precast panel label must be attached at mid-height, near the center of each wall panel. Additionally, each project must have at least one label on the foam insulation of one panel noting the name of the manufacturer, the name of the installer, and the manufactured and installation dates.
- 7.3 The report holder’s contact information is the following:
SUPERIOR WALLS OF AMERICA, LTD.
937 EAST EARL ROAD
NEW HOLLAND, PENNSYLVANIA 17557
(800) 452-9255
www.superiorwalls.com
- 7.4 The additional listees’ contact information is the following:
- SUPERIOR WALLS BY ADVANCED CONCRETE SYSTEMS, INC.**
55 ADVANCED LANE
MIDDLEBURG, PENNSYLVANIA 17842
- SUPERIOR WALLS OF CENTRAL VIRGINIA**
10101 SUPERIOR WAY
AMELIA, VIRGINIA 23002
- SUPERIOR WALLS BY COLLIER FOUNDATION SYSTEMS INC.**
1500 ELLSWORTH AVENUE, SUITE 210
HEIDELBERG, PENNSYLVANIA 15106
- SUPERIOR WALLS BY WARRIOR PRECAST, LLC**
DBA: SUPERIOR WALLS OF EAST TENNESSEE
10144 SPARTA HIGHWAY
ROCK ISLAND, TENNESSEE 38581
- SUPERIOR WALLS SYSTEMS, LLC**
DBA: SUPERIOR WALLS OF NORTH CAROLINA
3570 SOUTH MAIN STREET
SALISBURY, NORTH CAROLINA 28147
- NORTHEAST PRECAST**
DBA: SUPERIOR WALLS OF NEW JERSEY
4081 S. LINCOLN AVENUE
VINELAND, NEW JERSEY 08361
- SUPERIOR WALLS OF UPSTATE NEW YORK**
7574 EAST MAIN ROAD
LIMA, NEW YORK 14485
- WEAVER SUPERIOR WALLS, LLC**
DBA: SUPERIOR WALLS BY WEAVER PRECAST
824 EAST MAIN STREET
EPHRATA, PENNSYLVANIA 17522
- GREAT LAKES SUPERIOR WALLS**
4555 134TH AVENUE
HAMILTON, MICHIGAN 49419
- SUPERIOR CONCRETE BLOCK COMPANY**
401 SOUTH MCKINZIE STREET
MANKATO, MINNESOTA 56001
- ROCKY MOUNTAIN PRECAST, LLC**
1010 BIRCH STREET
NUNN, COLORADA 80648

TABLE 1—MINIMUM DEPTH OF CRUSHED STONE FOOTING (inches)

| CONSTRUCTION TYPE (Assumed Wall Loading) | | SOIL TYPE AND LOAD BEARING CAPACITY (psf) | | | |
|---|--------------------------------|---|--------------------------|--------|-------|
| | | 1,500 | 2,000 | 3,000 | 4,000 |
| | | MH, CH, CL, ML | SC, GC, SM, GM SP, SW | GP, GW | |
| Conventional Light-frame Construction | | | | | |
| 1-story | (1,100 pounds per linear foot) | 4 | 4 | 4 | 4 |
| 2-story | (1,800 pounds per linear foot) | 4 | 4 | 4 | 4 |
| 3-story | (2,900 pounds per linear foot) | 12 ¹ | 8 | 4 | 4 |
| Masonry Veneer over Light-frame Construction | | | | | |
| 1-story | (1,500 pounds per linear foot) | 4 | 4 | 4 | 4 |
| 2-story | (2,700 pounds per linear foot) | 10 ¹ | 6 | 4 | 4 |
| 3-story | (4,000 pounds per linear foot) | 20 ¹ | 12 ¹ | 6 | 4 |

For **SI**: 1 inch = 25.4 mm, 1 psf = 0.0479 kN/m², 1 plf = 14.6 N/m.

¹Stone must be vibrated in a maximum 8-inch lifts.

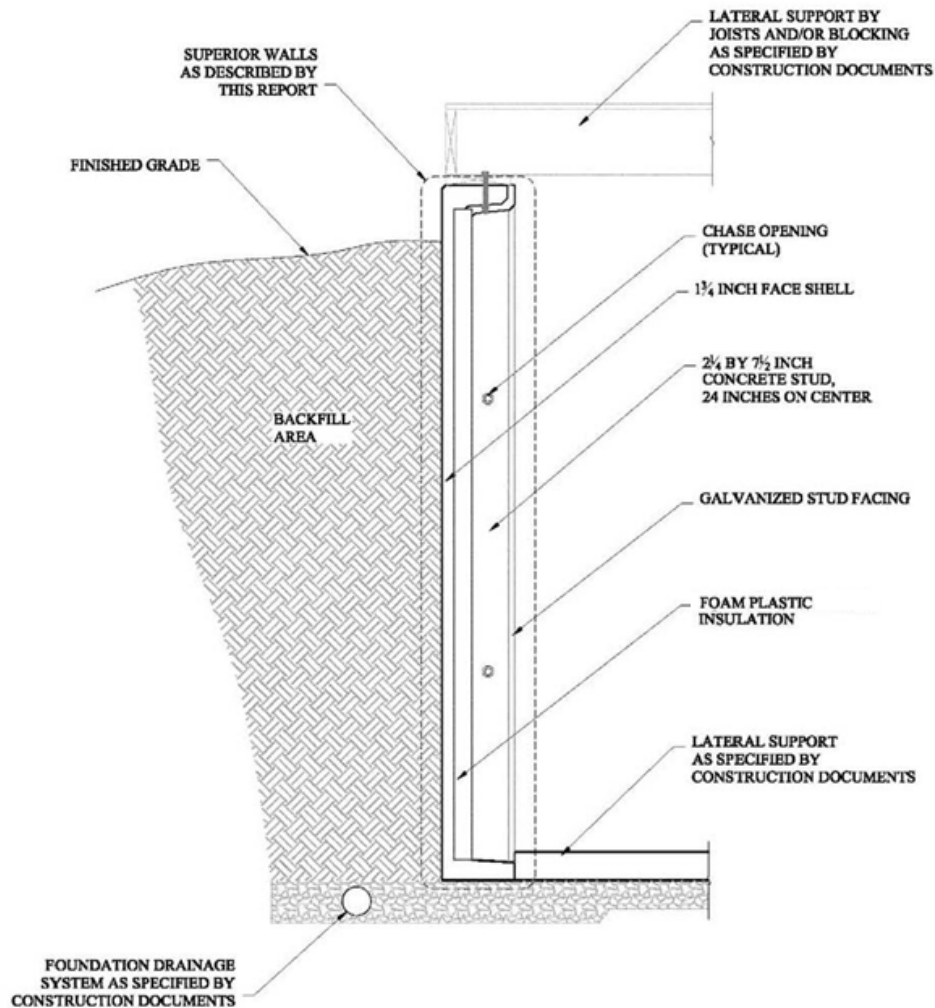

FIGURE 1—TYPICAL SUPERIOR WALL VERTICAL SECTION DETAIL

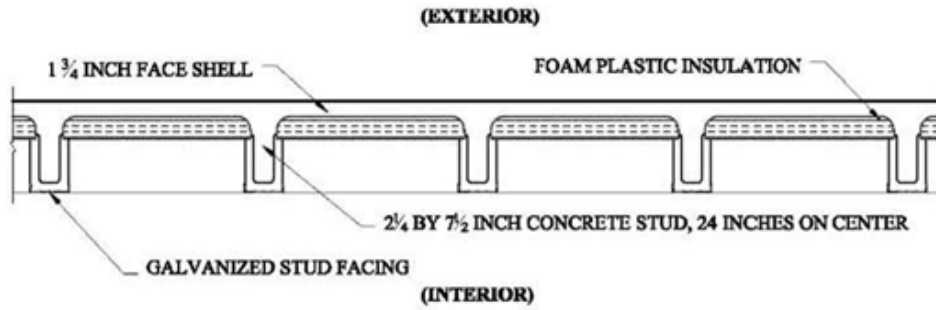

FIGURE 2—TYPICAL SUPERIOR WALL HORIZONTAL SECTION DETAIL

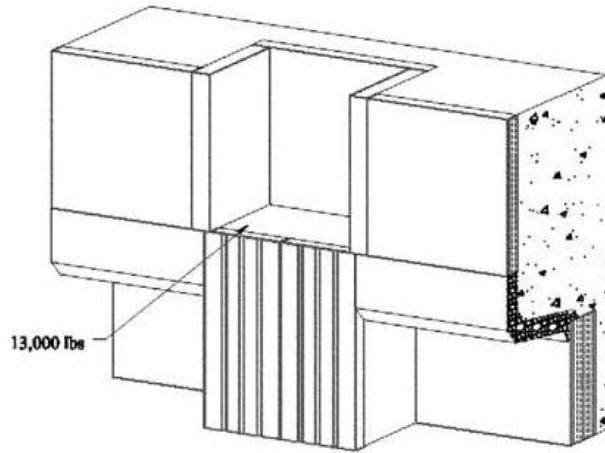
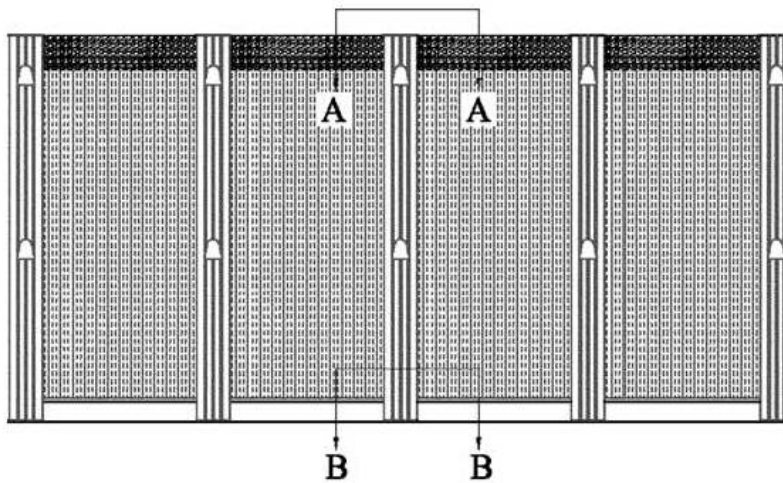

FIGURE 3—TYPICAL BEAM POCKET DETAIL



ELEVATION

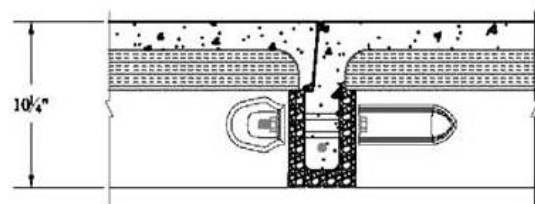
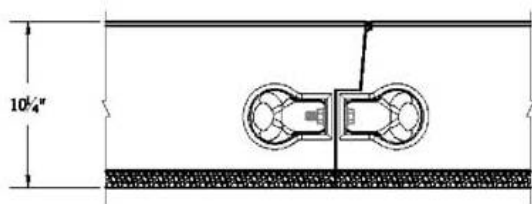

FIGURE 4—TYPICAL WALL CONNECTION DETAIL